

■ SCOPE OF WORK

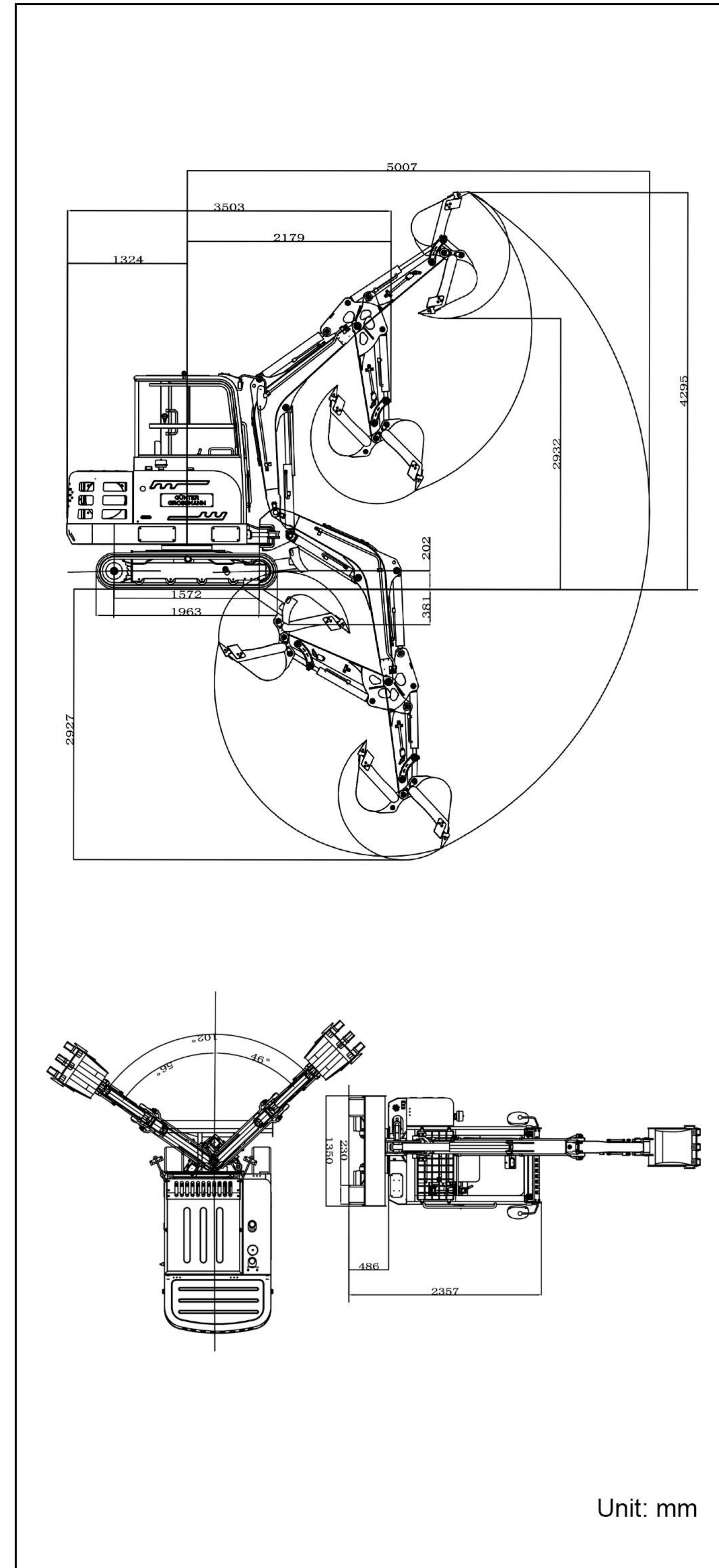

■ SPECIFICATION

	Model	unit	R350
Basic parameters	Machine working weight (kg)	lb(kg)	5683(2578)
	Bucket capacity	ft³(m³)	2.83(0.08)
	Travel speed low/high speed	mph(Km/h)	0-0.932(0-1.5)
	Gradeability	(%)	(30%)
	Ground pressure	psi(Kpa)	760.23(36.4)
	Maximum digging force	lbf(kN)	5058.2(22.5)
	Maximum digging radius	in(mm)	197(5007)
	Maximum digging depth (mm)	in(mm)	115.2(2927)
	Maximum digging height (mm)	in(mm)	169(4295)
	Maximum unloading height (mm)	in(mm)	115.4(2932)
Maximum deflection angle (°)	(°)	(102)	
Track extension range (mm)	in(mm)	-	
Engine	Engine brand		Kubota
	Engine model		V1505
	Maximum horsepower (ps)	hp	22.9
	Maximum power (Kw)	kw	17.1
	Maximum speed (rpm)	(rpm)	2300
	Displacement (L)	gal(L)	0.33(1.5)
	Number of cylinders		4
	Cooling method		Water-cooled
	Engine oil change amount (L)	gal(L)	1.32(5)
	Fuel form		DIESEL
Fuel grade		0/-10	
Theoretical fuel consumption (L/h)	(L/h)	1.3-1.5	
Body	Transport length (mm)	in(mm)	137.91(3503)
	Transport width (mm)	in(mm)	53.15(1350)
	Transport height (mm)	in(mm)	92.8(2357)
	Counterweight ground clearance (mm)	in(mm)	19.13(486)
	Bucket width (mm)	in(mm)	15.7(400)
	Boom length (mm)	in(mm)	87.4(2220)
	Arm length (mm)	in(mm)	63.78(1620)
	Bulldozer blade width (mm)	in(mm)	53.15(1350)

■ HYDRAULIC SYSTEM

Main pump type/model	28ml/r	Maximum set pressure	20MPa
Main pump brand	Taiming	Travel hydraulic motor type	Zhenjiang BWV-1000WCD modification type
Main pump maximum flow (L/min)	64.4	Travel motor brand	Zhenjiang Dali
Multi-way valve	8-way hydraulic control multi way valve	Motor displacement	990
Multi-way valve brand	Taiming	Slewing hydraulic motor type	Paiyi 2.5K
Rated set pressure	18MPa	Displacement	245

- Please read the operator's manual carefully before use and operate the machine correctly.
- Always wear the seat belt during operation. (ROPS models only)
- Only trained and qualified personnel should operate this machine in accordance with local laws and regulations.
- Inspect the machine regularly before and during operation to help prevent accidents, damage, and unexpected downtime.
- Perform routine maintenance and safety inspections according to the maintenance schedule in the operator's manual.
- Repairs, inspections, and servicing should be carried out by qualified technicians or authorized service personnel.



MINI EXCAVATOR R350



HOT SELLING MINI EXCAVATORS SUPPORT FACTORY CUSTOMIZATION



All-round cab, good sight line, can be equipped with airconditioning, comfortable operating environment.

Using high-pressure iron pipe, long life, not easy to damage.

Flip-top body, easy to check vehicle status and maintain.

The oil pipe is led to the stick, and it is more convenient to install the adapter.

Using Zhenjiang Dali BMV-1000 travel motor, torque.

The one-piece forged cylinder rod is used, which will not break and

The track belt is wide, thick and durable, and can be used in a variety of environments, effectively improving work efficiency.

The big arm can be deflected to perform operations at various angles and improve work efficiency.

Bucket spur teeth are detachable, easy to replace after wear.



Product introduction



All-round cab, good sight line, can be equipped with air conditioning, comfortable operating environment.

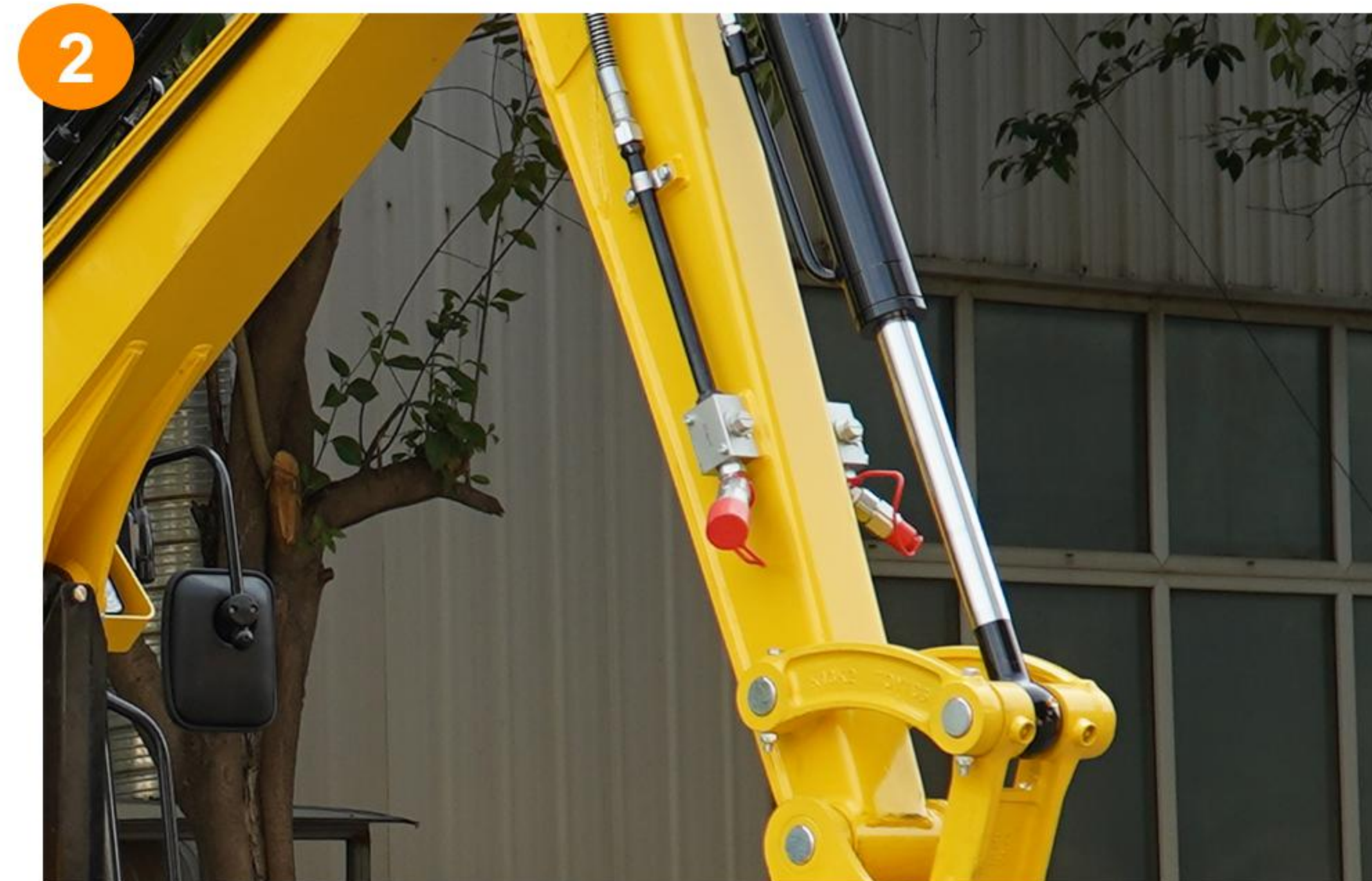

The breaker stop valve can effectively prevent oil leakage from the broken oil pipe when installing the breaker.

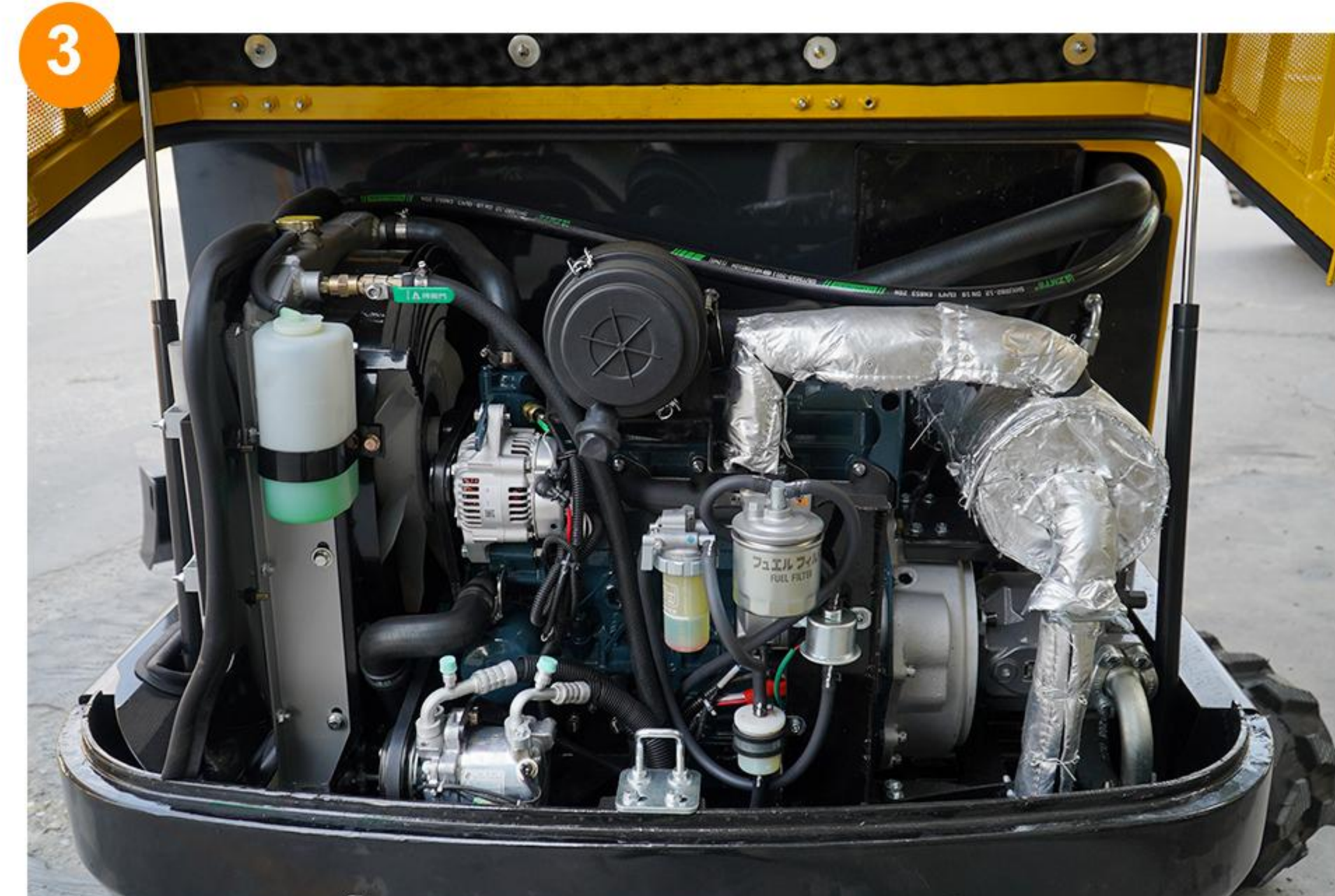

The R350 3.5-ton mini excavator can be equipped with Kubota engine/ Changchai engine/Xinchai engine to meet the needs of different countries at home and abroad;



The double-layer widened and thickened bulldozer has a longer service life.



- The vehicle is equipped with a rearview mirror to facilitate observation of the real-time status behind the vehicle and safe driving.
- The oil cylinder is equipped with a protective cover to better protect the oil cylinder and avoid malfunctions caused by bumps during operation.
- The side swing of the big arm enables multi-angle operation, effectively improving work efficiency.

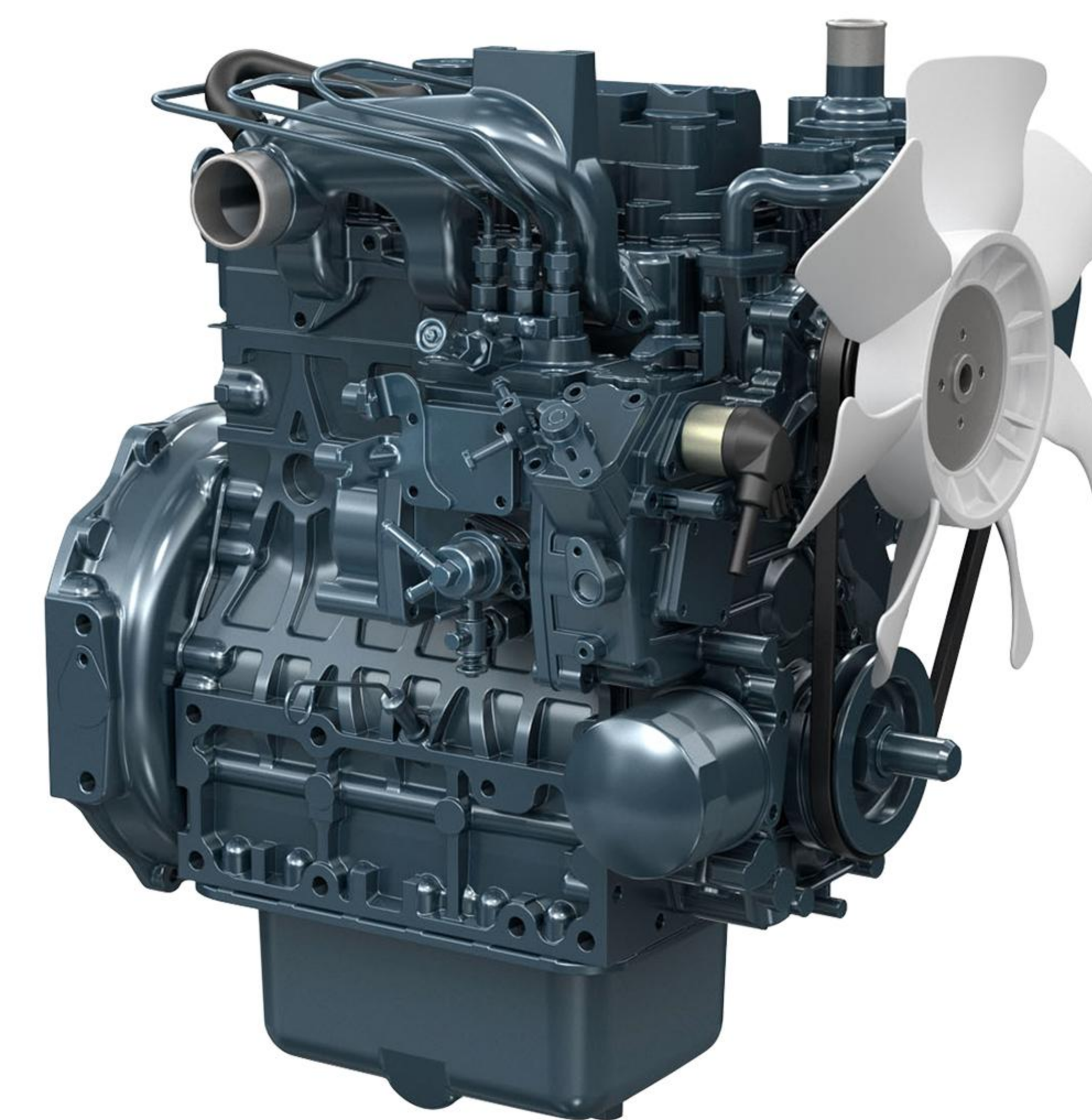

KUBOTA ENGINE

While ensuring high power output of the engine, energy saving and environmental protection can be achieved. Comply with EPA4 and Euro 5 standards. Low noise, low emissions, no impact on people and the environment.

- Adding an air pre-filter can make the fuel burn more completely and save fuel.
- The flip-up rear cover makes maintenance more convenient.
- The extra-large cooling water tank is corrosion-resistant, has a large cooling area, is shock-resistant, collision-resistant and has a long service life.

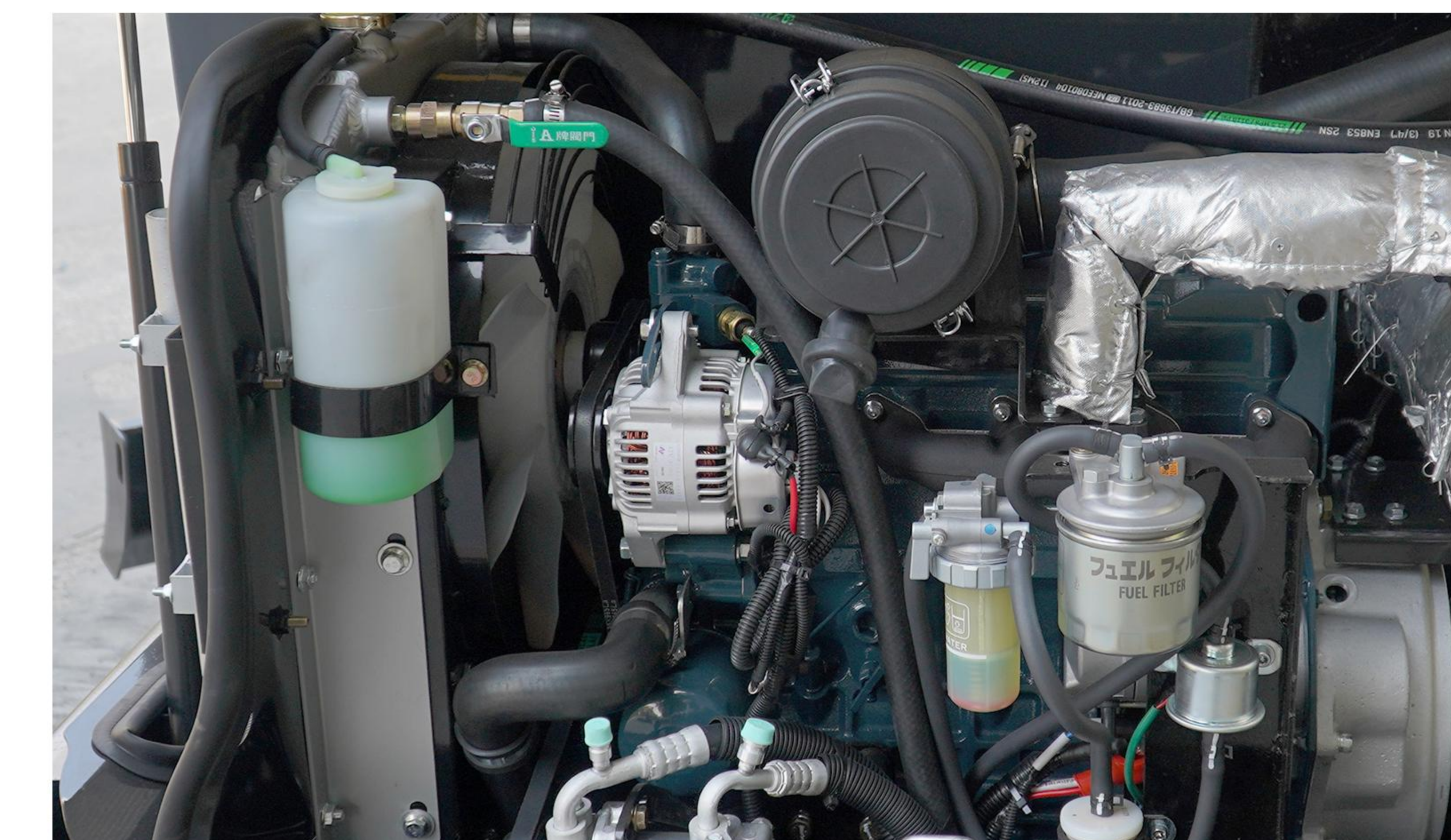

SOLID BOTTOM PLATE



[X-SHAPED FRAME DESIGN]

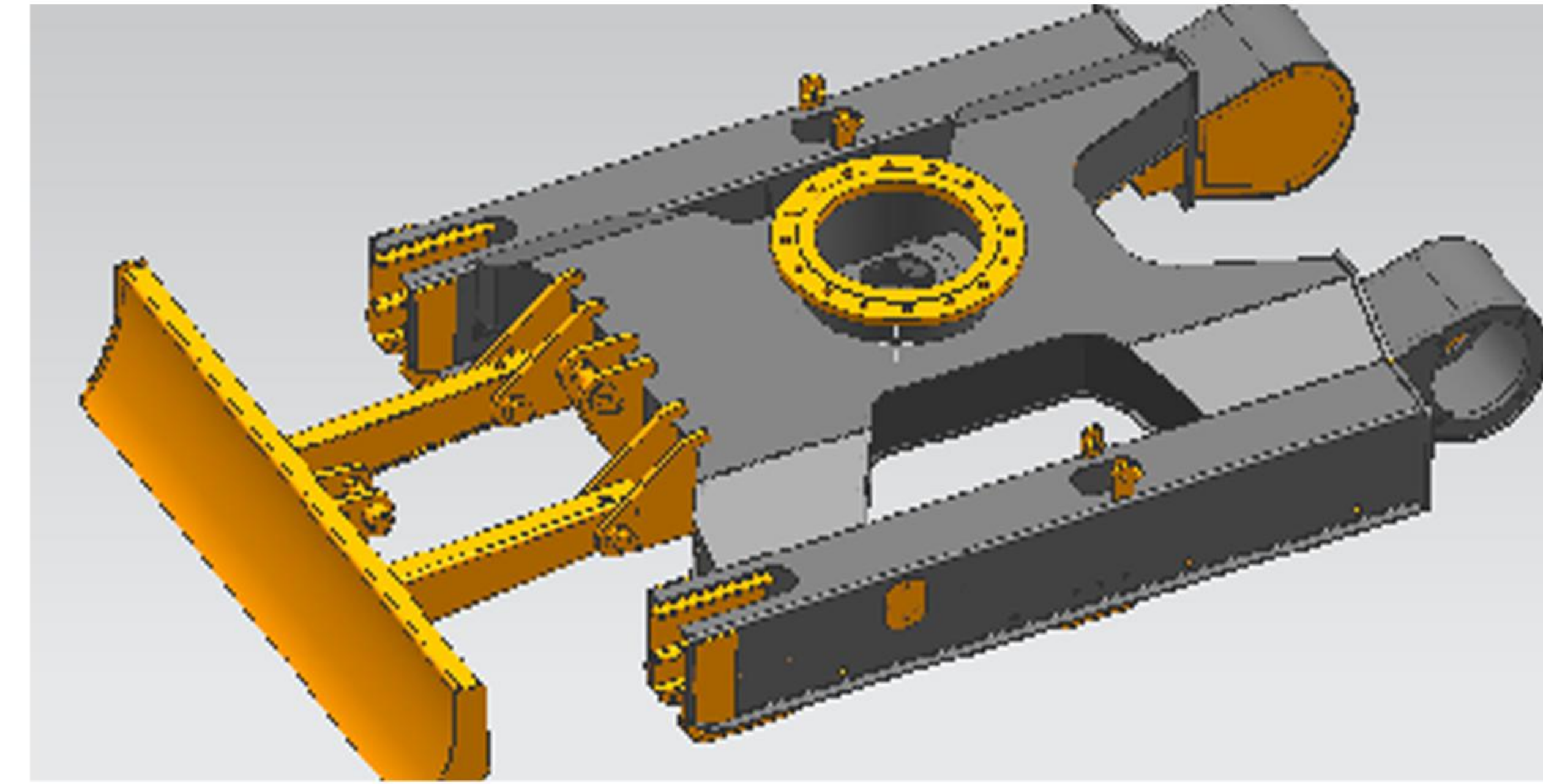

The lower plate adopts an X-shaped frame design, which has the functions of moving forward, backward and turning. The crawler chassis adopts Komatsu excavator technology, with strong carrying capacity and traction, and has good transportation performance to avoid damage to asphalt roads.

[TRAVEL MOTOR]

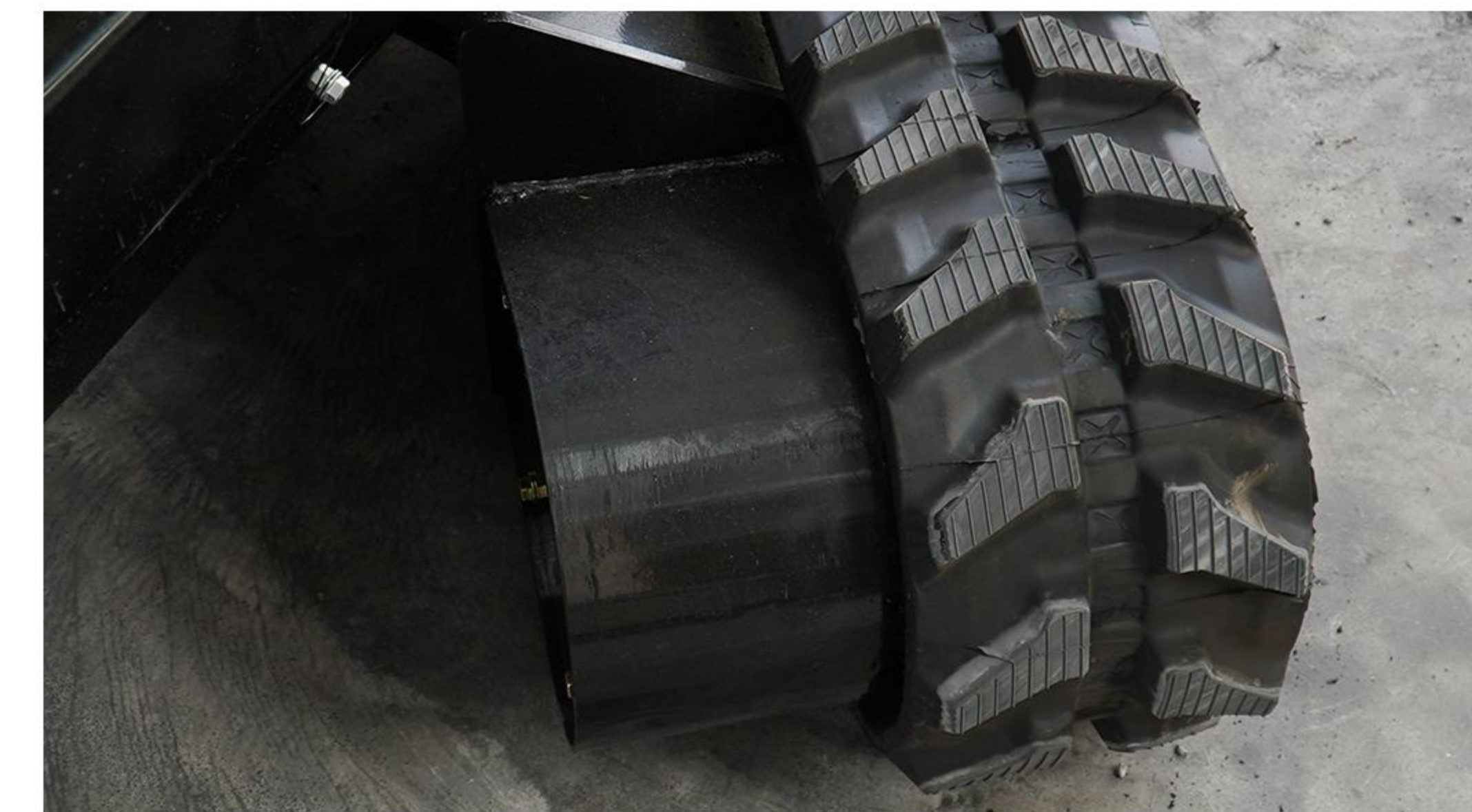

The travel motor is internally enclosed, which effectively protects the travel motor and prevents external influences and bumps.

[ROTATING DEVICE]



The tooth surface is quenched to greatly enhance the hardness of the tooth surface, improve the working strength and service life

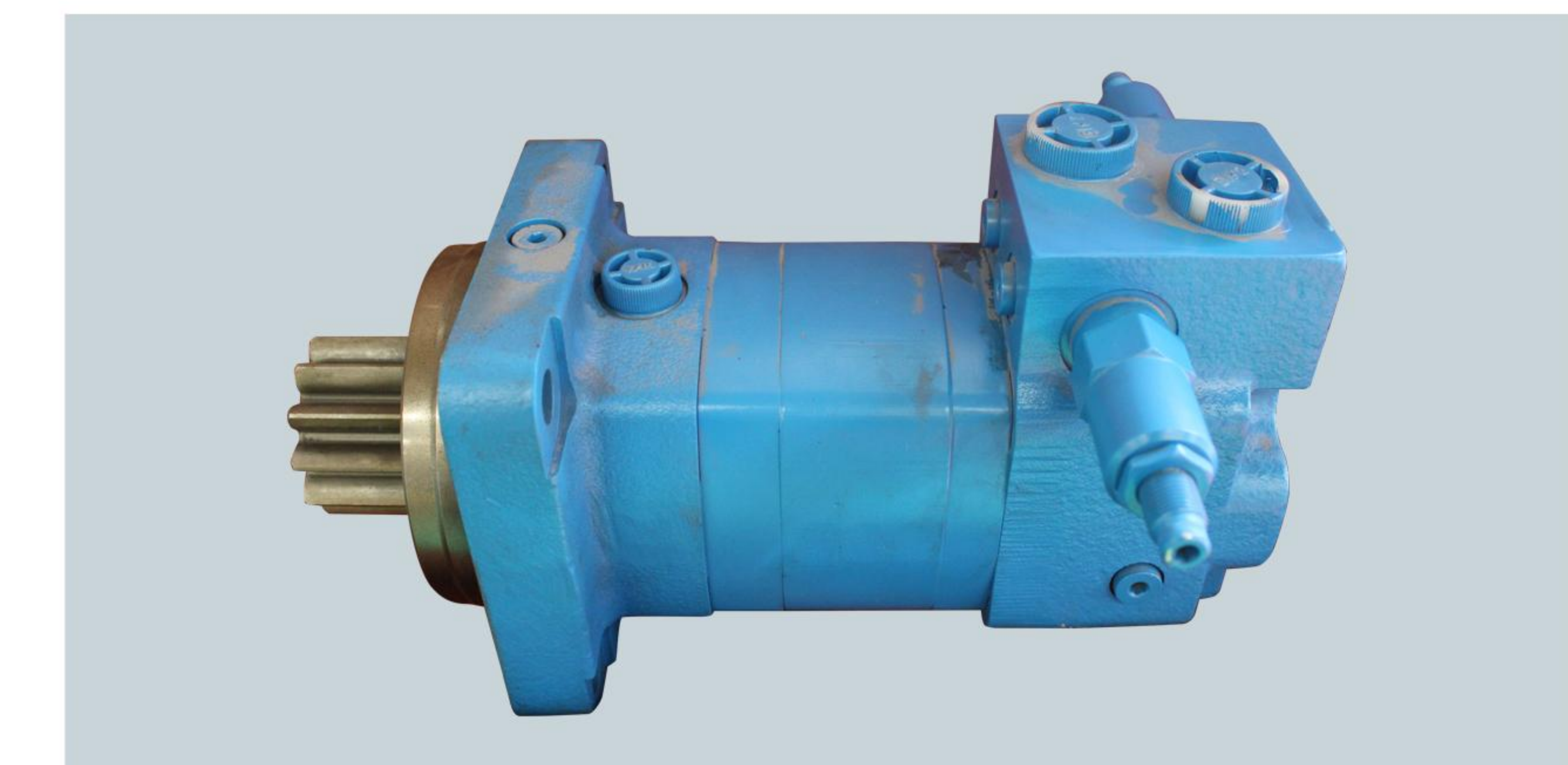

The rotary hydraulic motor comes with a valve group that can balance the oil circuit, replenish oil, and control flow, with reliable quality

[WALKING DEVICE]

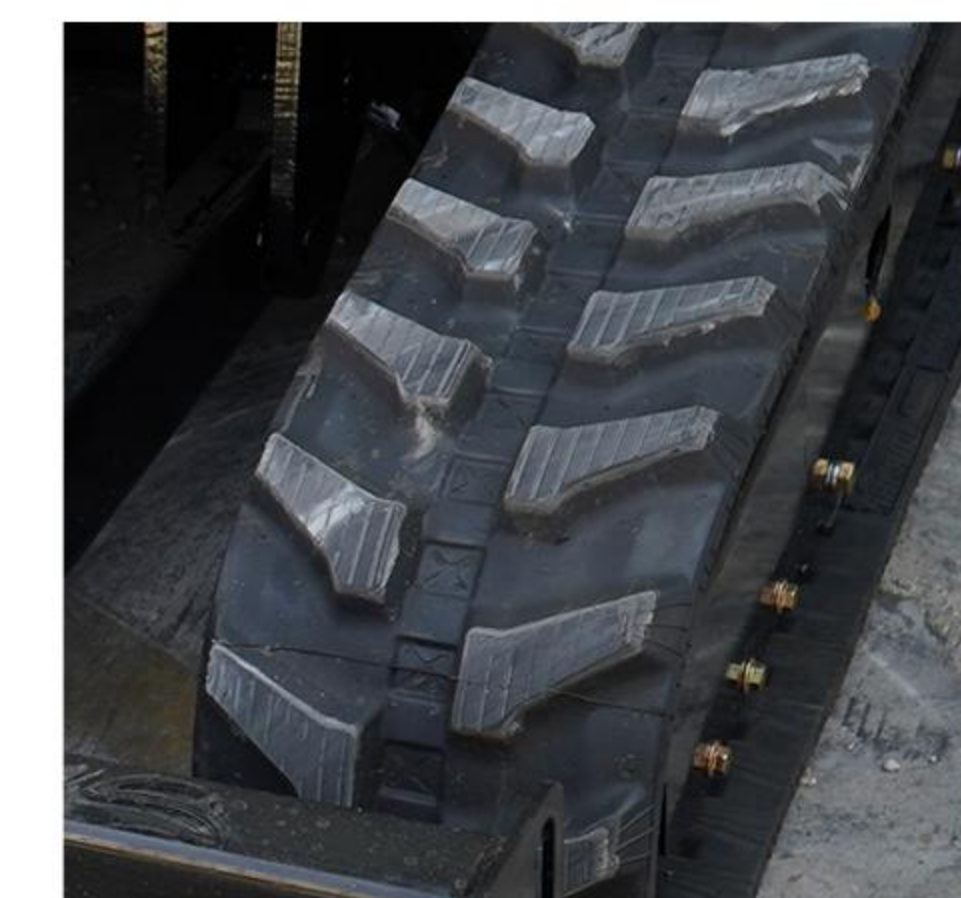

The guide wheel and tensioner can guide the direction and tighten the track.

The sprocket wheels hold the track to prevent it from sagging too much.

Herringbone engineering rubber track, strong, durable and stable

WE ARE RIPPA

Shandong Rippa Machinery Group Co., Ltd. is located in the No. 39, Guang'an Road, Liu-hang Sub-district Office, High-tech Zone, Jining City, Shandong Province, It is a state-owned high-tech enterprise with import and export rights.

The company's employees are energetic and enterprising, constantly creating the legend and fame of the rippa!



Shandong Rippa Machinery Group Co., Ltd.

Address: No. 39, Guang'an Road, Liu-hang Sub-district Office, High-tech Zone, Jining City, Shandong Province

Some specifications are based on engineering measurements and may differ from actual conditions. Specifications are for comparison purposes only and are subject to change without notice. Specifications of individual RIPPA devices may vary due to normal variations in design, manufacturing, operating conditions and other factors. Some images of RIPPA devices are not limited to standard packages.



www.rippa.com